



Email Marketing and Marketing Automation

ClickDimensions is a software-as-a-service marketing automation solution that embeds email marketing, web intelligence, campaign automation, lead scoring, event management, campaign tracking, landing pages, forms, surveys and more directly into Microsoft Dynamics 365 (CRM).

Email Marketing

Send bulk email to marketing lists, send email to individuals directly, or trigger emails to be sent by CRM workflow. All tracking comes back into CRM so the results are visible and actionable.

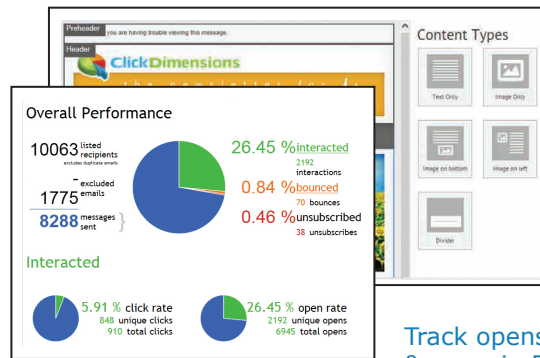

Drag and drop designer makes creating emails easy!

Track opens, clicks, bounces & more in Dynamics 365

Campaign Automation

Put your sales and marketing campaigns on auto-pilot with a campaign automation builder. The drag-and-drop interface allows you to easily build automated campaigns with a variety of triggers, timers and actions. Design unique paths for contacts or leads to follow as they interact with your marketing messages.

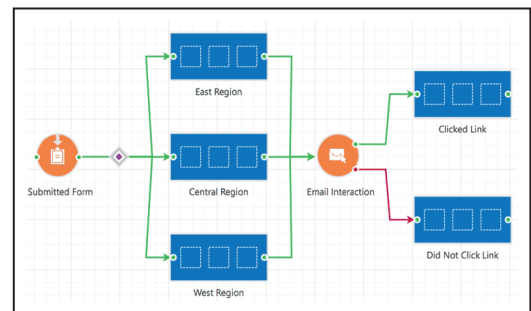

Create dynamic, customised experiences for your prospects, leads, or customers

Web Intelligence

Discover who is interested in your products and services by viewing the actual web activity of anonymous and identified visitors on your website. Interested in which companies and organisations are browsing your site and what interests them? Want to know what a specific prospective customer has viewed on your site before making the opening call? Our software allows you to do all this and more.

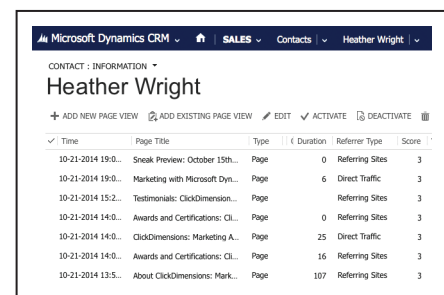

Time	Page Title	Type	Duration	Referrer Type	Score
10-21-2014 19:00...	Sneak Preview: October 19th...	Page	0	Referring Sites	3
10-21-2014 19:00...	Marketing with Microsoft Dyn...	Page	6	Direct Traffic	3
10-21-2014 15:20...	Testimonials: ClickDimension...	Page	0	Referring Sites	3
10-21-2014 14:00...	Awards and Certifications: Cl...	Page	0	Referring Sites	3
10-21-2014 14:00...	ClickDimensions: Marketing A...	Page	25	Direct Traffic	3
10-21-2014 14:00...	Awards and Certifications: Cl...	Page	16	Referring Sites	3
10-21-2014 13:5...	About ClickDimensions: Mark...	Page	107	Referring Sites	3

Receive a list of real-time visits from leads, contacts and anonymous visitors

Lead Scoring

As this software tracks individual visitor activity on your website, each visitor accumulates a score based on his or her visits, page views, email clicks and more. Scoring is based on default values you set, but you may also score certain pages higher or lower based on their importance in showing visitor intent. Using the lead score, your sales team can quickly and easily determine which leads to pursue.

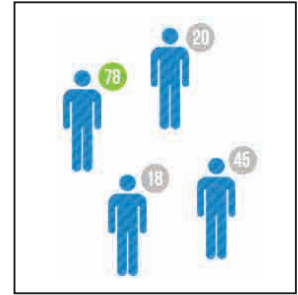

Form Integration

Its so easy to create web forms with our drag and drop design function. You can also integrate your website's existing forms into Microsoft Dynamics 365.

When a visitor completes a form, his or her email address is checked against all email addresses in CRM to avoid duplicate data. Lead or contact records can be created for visitors who are not already in your CRM and all the data the visitor submits on the form is linked to their CRM record.

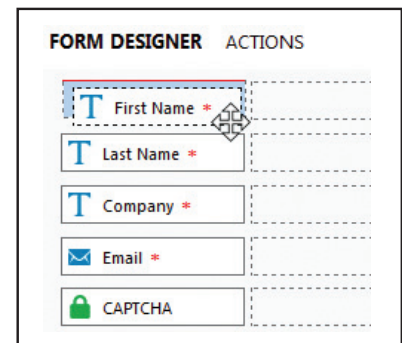

Use our drag and drop designer to quickly create forms and embed them into your website

Surveys

Create surveys with our drag and drop survey designer. Surveys may be emailed to leads, contacts and accounts and may even be linked to case records.

Surveys may also be posted as pages so they can be completed by anonymous visitors. When a respondent completes a survey, all the data the visitor submits is linked to their CRM record.

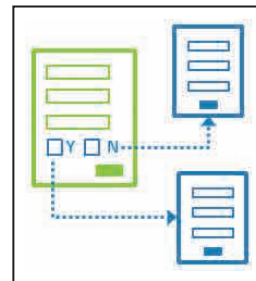

Incorporate skip logic into your surveys to skip questions and pages based on certain answers

Reporting

Maximize the convenience of having ClickDimensions native inside Microsoft Dynamics 365 through integrated reporting. Link emails, web visits, page views, and form captures directly to CRM campaign records. The content pack for Power BI allows users to utilize marketing data in Power BI, giving management teams further insight into the success of their sales and marketing efforts.



Analyse and visualise marketing data in Power BI dashboards and reports



About Formus Pro

Professional software, solutions and support for growing businesses.

With offices in the UK and packages that support you, as well as your set up.

We offer a personal service that makes the business of doing business that much easier.